

Electro-pneumatic drilling units Elektropneumatische Bohreinheiten

	THRUST VORSCHUBKRAFT	4000 N
	WEIGHT GEWICHT	45-49 Kg

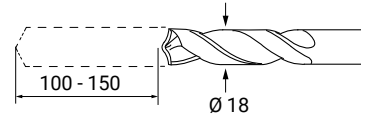

DRILLING CAPACITY IN STEEL R=60
BOHRLEISTUNG IN STAHL R=60

Ø 18

STROKE
HUB

100 mm
150 mm

TOOLHOLDER
WERKZEUGAUFNAHME

B = B18 DIN 238 H = DIN 55058 Ø 28
D1 = MORSE 2 N = ER32

SPINDLE RPM (50HZ) / SPINDEL DREHZAHL

A	160	R6P	CHAIN WITH REDUCER GETRIEBEKETTE
B	200		
C	250		
D	300		
E	400	6P	CHAIN KETTE
F	500		
G	600	4P	TIMING BELT ZAHNRIEMEN
H	800		
I	1000		
J	1200		
K	1500	2P	POLY-V BELT POLY-V RIEMEN
L	1800		
M	2000	2P	POLY-V BELT POLY-V RIEMEN
N	2400		
O	3000	2P	POLY-V BELT POLY-V RIEMEN
P	3600		
Q	4000	2P	POLY-V BELT POLY-V RIEMEN
R	4500		

DXP 18 /.. /.. /.. /.. /..

MOTOR / MOTOR

205	=	90	-	1,50 kW	2P
406	=	90	-	1,50 kW	4P
606	=	90	-	1,10 kW	6P

Max frame 112 / Max Größe 112

HYDROCHECK / HYDRAULIKBREMSE

HF50 = STROKE/ HUB 50 mm
HF75 = STROKE/ HUB 75 mm
HF100 = STROKE/ HUB 100 mm

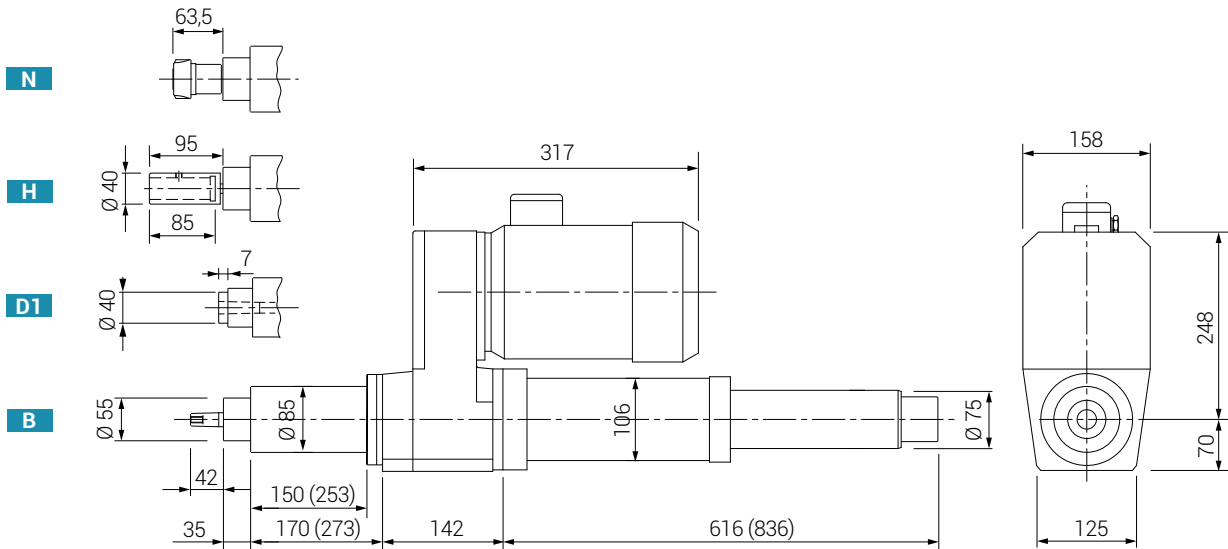

Dimension () are for the 150 mm stroke unit / (Quoten) = Einheit mit Hub 150

ACCESSORIES

(Page 40)

- Multi spindle heads
- Pneumatic peck feed device
- For brackets see 3D pictures

ZUBEHÖR

(Seite 40)

- Mehrspindelköpfe
- Pneumatische Entspäeinrichtung
- Zubehör siehe 3D Abbildung

